



GAS

GRIDDLES | THERMOSTATIC CONTROLS

IMPERIAL



ITG-36

Model Numbers

ITG-24

ITG-36

ITG-48

ITG-60

ITG-72

BURNERS

- Thermostat maintains selected temperature during peak hours.
- Each griddle burner is rated at 30,000 BTU (9KW).
- Aeration baffles between burners spread the heat evenly across the entire griddle surface.
- Burners are located every 12" (305 mm).
- Each burner has an adjustable gas valve and continuous pilot for instant ignition.

GRIDDLE PLATE

- Highly polished 1" (25 mm) thick steel plate holds temperature and has a quick recovery.
- ~~Full 24" (610 mm) plate depth~~ for more cooking surface. **Built with 30" Depth**
- Surface is ideal for a large range of menu items.
- **Optional chrome** and grooved griddle top are available as an option.

GREASE MAINTENANCE

- Stainless steel grease gutter is 4" (102 mm) wide.
- Large 1 gal (3.8 L) capacity grease can has a weep hole to indicate when full.
- Grease can removes easily.



4" (102) WIDE GREASE GUTTER AND 1 GAL. (3.8 L) GREASE CAN

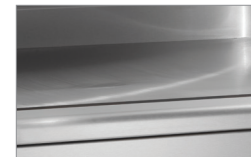

THICK HIGHLY POLISHED STEEL GRIDDLE PLATE MAINTAINS SELECTED TEMPERATURE.

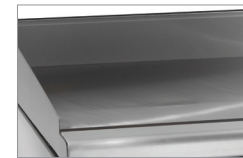

FULL WIDTH REAR FLUE DISTRIBUTES HEAT UNIFORMLY ACROSS THE GRIDDLE SURFACE.

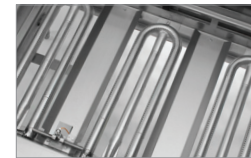

AERATION BAFFLES BETWEEN BURNERS SPREAD HEAT ACROSS GRIDDLE FOR MORE EVEN HEATING.

EXTERIOR

- Stainless steel front, sides, splash guard, and ledge.
- Stainless steel ledge is one piece rolled for cleaning convenience.
- Range match profile when placed on a refrigerated base or equipment stand.
- Control knobs are cast aluminum with a Valox™ heat protection grip.
- 4" (102 mm) stainless steel legs are included.
- ~~One-year parts and labor warranty.~~

Gator Chef's Limited 90-Day Used Equipment Warranty. Call Gator Chef for warranty details.



GAS

GRIDDLES | THERMOSTATIC CONTROLS

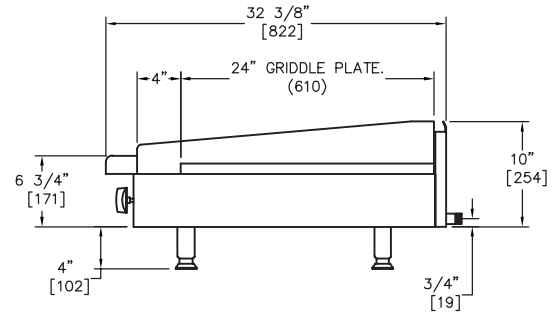
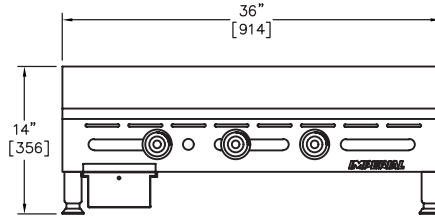
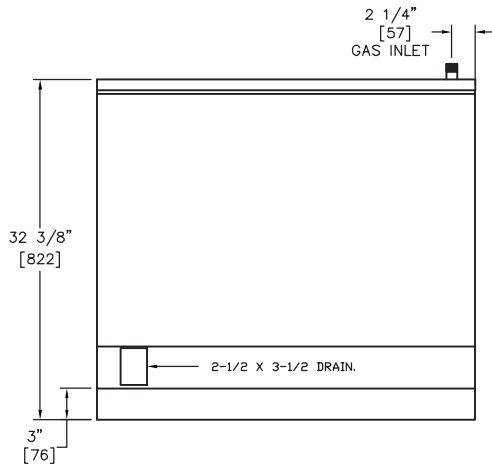

THERMOSTATICALLY CONTROLLED GRIDDLES

MODEL	WIDTH IN (MM)	BURNERS	GAS OUTPUT BTU (KW)	SHIP WEIGHT (KG) LBS
ITG-24	24" (610)	2	60,000 (18)	(136) 300
ITG-36	36" (914)	3	90,000 (26)	(195) 430
ITG-48	48" (1219)	4	120,000 (35)	(261) 575
ITG-60	60" (1524)	5	150,000 (44)	(328) 725
ITG-72	72" (1829)	6	180,000 (53)	(396) 875

MODEL	GRIDDLE PLATE DIMENSIONS	DIMENSIONS	CRATED DIMENSIONS
ITG-24	24" W X 24" D (610 X 610 MM)	24" W X 32-3/8" D X 14" H (610 X 822 X 356 MM)	26-1/2" W X 36" D X 16-1/2" H (673 X 914 X 419 MM)
ITG-36	36" W X 24" D (914 X 610 MM)	36" W X 32-3/8" D X 14" H (914 X 822 X 356 MM)	38-1/2" W X 36" D X 16-1/2" H (978 X 914 X 419 MM)
ITG-48	48" W X 24" D (1219 X 610 MM)	48" W X 32-3/8" D X 14" H (1219 X 822 X 356 MM)	50-1/2" W X 36" D X 16-1/2" H (1283 X 914 X 419 MM)
ITG-60	60" W X 24" D (1524 X 610 MM)	60" W X 32-3/8" D X 14" H (1524 X 822 X 356 MM)	62-1/2" W X 36" D X 16-1/2" H (1588 X 914 X 419 MM)
ITG-72	72" W X 24" D (1829 X 610 MM)	72" W X 32-3/8" D X 14" H (1829 X 822 X 356 MM)	74-1/2" W X 36" D X 16-1/2" H (1892 X 914 X 419 MM)

Built with 30" Depth
OVERALL: 48"W x 30"D

OPTIONS AND ACCESSORIES

- Stainless steel equipment stands
- 6" (152 mm) casters for equipment stands
- Open burners available, set of 4 burners, add 24" (610 mm) to width and "OB-4" to model number
- Open burners available, set of 2 burners, add 12" (305 mm) to width and "OB-2" to model number
- 7" (178 mm) deep, stainless steel front landing ledge
- 9" (229 mm) deep, stainless steel front landing ledge
- **Chrome griddle top, (add "-CG" to model number)**
- Extra grease can

CLEARANCE REQUIREMENTS

For use only on non-combustible surfaces. Provide 0" clearance from non-combustible surfaces and 6" (152 mm) from combustible surfaces.

MANIFOLD PRESSURE		
NATURAL GAS	PROPANE GAS	MANIFOLD SIZE
5.0" W.C.	10.0" W.C.	3/4" (19 MM)

